

ORANGE COUNTY FIRE AUTHORITY

Community Risk Reduction

1 Fire Authority Road, Building A, Irvine, CA 92602 www.ocfa.org 714-573-6100

High-Piled Combustible Storage



Guideline G-09

Serving the Cities of Aliso Viejo • Buena Park • Cypress • Dana Point • Garden Grove • Irvine • Laguna Hills • Laguna Niguel • Laguna Woods
Lake Forest • La Palma • Los Alamitos • Mission Viejo • Rancho Santa Margarita • San Clemente • San Juan Capistrano • Seal Beach
Santa Ana • Stanton • Tustin • Villa Park • Westminster • Yorba Linda and Unincorporated Areas of Orange County

High-Piled Combustible Storage

PURPOSE

The intent of this guideline is to provide the requirements for the protection of high-piled storage (HPS) for a variety of commodities. HPS increases the potential fire hazard within a structure by increasing the vertical height of storage and by providing stability of storage (e.g., rack and automated storage) in a fire situation. The following requirements will ensure that the minimum measures required by code have been taken to provide for the public's safety and that the required protection of these commodities has been designed in accordance with Chapter 32 of the 2019 California Fire Code (CFC), the 2019 California Building Code (CBC) and locally adopted ordinances enforced by Orange County Fire Authority (OCFA).

SCOPE

This guideline provides the Fire Department's requirements for all HPS within the jurisdiction of the OCFA. This does not address the structural design for stability of the storage required by the Building Safety Departments.

For the purposes of this guideline, certain terms are defined as follows:

Commodity: The combination of products, packing material, and container that determines commodity classification. (NFPA 13 Section 3.9.1.5)

Free-Flowing Plastic Materials: Those plastics that fall out of their containers during a fire, fill flue spaces, and create a smothering effect on the fire. Examples include powder, pellets, flakes, or random-packed small objects [e.g., razor blade dispensers, 1 oz. to 2 oz. bottles]. (NFPA 13 Section 3.9.1.14)

High-Piled Combustible Storage: The storage of combustible materials in closely packed piles, on pallets, in racks, or on shelves where the top of storage is greater than 12 feet in height. High-piled combustible storage also includes certain high-hazard commodities, such as rubber tires, Group A plastics, flammable and combustible liquids, idle pallets, and similar commodities where the top of storage is greater than 6 feet in height. (CFC 3202)

Note: To be considered non-high pile combustible storage for high hazard commodities ≤ 6 feet there cannot be any storage above it.

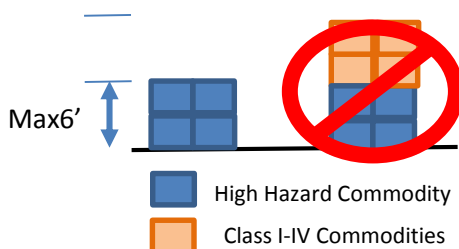

HPS Area: An area within a building that is designated, intended, proposed, or actually used for high-piled combustible storage. For purposes of selecting the applicable fire protection requirement row in Table 3206.2:

- This area shall include the “footprint” of the actual storage array (racks, shelves, fixtures, or pallets), inclusive of aisles within the storage area(s). When individual storage arrays are separated by less than 15 feet spaces, the spaces shall be considered aisles and shall be included in a single storage area footprint. When individual storage arrays are separated by more than 15 feet spaces, the individual arrays shall be considered separate storage areas with their own footprint calculation. (CFC 3206.2)
- Each storage area shall also include a 48 inch perimeter aisle calculated in the footprint. This additional perimeter aisle is not required for areas that abut to a wall. The aisle is the space between the racks, not at the end of the rack.
- For multiple storage areas within a building, the aggregate of all HPS areas shall be used for selecting the applicable row in Table 3206.2, unless such areas are separated from each other by a one-hour rated fire barrier wall constructed in accordance with Section 707 of the California Building Code (CBC). Openings in such walls shall be protected by fire assemblies having a one-hour fire-protection rating. (CFC 3206.3.2.1)
- A fire safety and evacuation plan(s) shall be submitted at the time of plan submittal for review and approval where required by Section 403 CFC 3201.4.

Listed-plastic pallets: Plastic pallets listed and labeled in accordance with UL2335 or FM 4996 shall be treated as wood for determining required sprinkler protection.

Unreinforced plastic pallets: Unreinforced pallets shall be marked with a permanent symbol indicating the pallet is unreinforced. (CFC 3203.10.1)

Reinforced plastic pallets: Reinforced polypropylene or reinforced high-density polyethylene plastic pallets. (CFC 3208.10.2)

Other pallets: Pallets other than polypropylene or high-density polyethylene plastic pallets. (CFC 3208.10.3)

Commodity Class I through IV may need to be increased:

1. Where unreinforced polypropylene or unreinforced high-density polyethylene plastic pallets are used, the commodity classification shall be increased one class; where unreinforced polypropylene or unreinforced high-density polyethylene plastic pallets are used, the commodity classification shall be increased two classes; where other pallets are used, the commodity classification shall be increased by two classes. *Exceptions - unless specific testing is conducted by a testing laboratory.*
2. The percentage of group A plastics shall be evaluated by:
 - a. Percentage by weight shall be determined per Equation 32-1
 - b. Percentage by volume shall be determined per Equation 32-2*Compare these results with the results from Figure 3203.9 (1) and / or Figure 3203.9 (2) and the highest classification will apply.*

Extent of protection: The fire safety features required in Table 3206.2 shall extend to the lesser of 15 feet beyond the HPS area or full height wall. Different commodity classifications need to be separated to the lesser of 15 feet beyond the commodity classification or full height wall. Where portions of the HPS areas have different fire protection requirements because of commodity, method of storage or storage height, the fire protection features required by Table 3206.2 within this area shall be based on the most restrictive design requirements. (CFC 3206.2.1)

Rack Storage: A combination of vertical, horizontal, and diagonal members that support stored materials. Racks can be fixed or portable. (NFPA13 Section 3.9.3.7)

Open Rack: Racks without shelving or with shelving in racks that are fixed in place with shelves having a solid surface and shelf area equal or less than 20 square feet or with shelves having a wire mesh, slatted surface, or other material with openings representing at least 50 percent of the shelf area including the horizontal area of the rack and where the flue spaces are maintained.

Shelf Storage: Storage on shelves less than 30 inches deep with the distance between shelves not exceeding 3 feet vertically. For larger shelves and other storage arrangements, see *Rack Storage*. (NFPA 13 Section 3.9.2.6)

Solid Shelving: Shelving that is solid, slatted, mesh, grated, or of other construction and less than 50 percent open; and located within racks that obstruct sprinkler water penetration through the racks. Within the codes that regulate HPS, there are two different thresholds when the size of the shelf is considered solid: the Fire Code specifies 32 square feet while NFPA 13 specifies 20 square feet. In sprinklered buildings, two factors are used to determine if the shelf is considered solid: the construction type of the shelf and the size of the product that will be stored on the shelf. If the item stored has a horizontal area that exceeds 20 square feet in size, the shelf is considered solid regardless of the construction of the shelf. As an example, the HPS uses wire mesh shelves with an opening greater than 50 percent. The commodity being stored is on a non-standard pallet of 4 feet deep by 6 feet wide, total horizontal size = 24 square feet. The shelving would be considered solid since the commodity exceeds 20 square feet irrespective that the shelf is wire mesh. (NFPA 13 Section 3.9.3.8)

SUBMITTAL REQUIREMENTS

General Requirements:

1. **California Fire Code Permits - CFC sub-3201.2:** Plans and specifications shall be submitted to the OCFA Planning and Development Services Section. All permits will be issued following plan approval and completion of corresponding inspections of the HPS installation. A CFC permit is required when a building or portion thereof is used for HPS exceeding 500 square feet in an area (see the definition of HPS area under "Scope"). CFC permit fees are invoiced annually.
2. At the time of permit application, plans and specifications, including but not limited to the information listed below, shall be submitted for review and approval. For

certain HPS reviews, the services of a design professional familiar with the requirements contained in CFC Chapter 32 may be of great assistance. All new plan submittals and revisions will consist of 2 plan hard copies and 1 electronic copy in PDF format. All electronic copies may be submitted on CD, DVD, or flash drive.

To determine whether an HPS plan is required to be submitted to OCFA, please refer to Attachment 10. If a submittal is required, plans shall include ALL of the following information per CFC 3201.3, items #A-R:

- A. A letter of intent containing a detailed description of the products to be stored and the description of all containers, pallets, and packaging materials. This letter must also include a detailed description of the storage methods (racks, shelves, and pallets), the total storage area in square feet, maximum storage height, aisle widths, and flue spaces. Within this letter, state that approved HPS plans will be maintained on site for the life of the HPS system(s). An authorized officer of the company or business must sign this letter. The letter shall be copied onto the plans.
- B. A scaled site plan that shows the entire building, including all fire access lanes, fire hydrants, fire department connection, and fire sprinkler risers. (CFC 3206.6)
- C. A scaled floor plan of the building showing locations and dimensions of the HPS area, location of the racks, and access doors to the storage area.
- D. The maximum desired/proposed storage height for each designated storage area per array. This height is measured from the finished floor to the highest point of the commodity stored (not shelf level).
- E. The number of tiers within each rack.
- F. The commodity clearance between the top of the storage and the sprinkler deflector for each storage arrangement.
- G. Aisle dimensions between each storage array. Aisles are measured from the actual edge of the commodity to commodity, not rack to rack.
- H. Maximum pile volume for each storage array for solid pile and shelf-storage.
- I. The location and classification of different commodity classes. In buildings with multi-tenant spaces, the plan shall show if the tenant spaces within the building are separated by a one-hour fire barrier, or that the adjacent tenant(s) does not have HPS. In the event that the adjacent tenant(s) does have HPS and are not separated by a one-hour fire barrier per CBC Section 707, the aggregate of all areas of HPS within the building shall be used for the application of Table 3206.2. Additionally, the provisions of CFC 3206.3.2.2 for multi-class HPS areas shall apply.
- J. The location of commodities that are banded or encapsulated.
- K. The dimension and location of the transverse and longitudinal flue spaces.
- L. The sprinkler design requirements based on commodity type, aisle width, and sprinkler temperature rating as outlined in NFPA 13, Chapter 12-18 (e.g., .45/3000 with 286-degree heads). A complete sprinkler design shall be submitted under a separate Service Request number by a C16 licensed contractor.

- M. The location of all steel columns in relationship to the racks. All steel columns located within a rack flue space or immediately adjacent to a rack in an aisle may require protection. See NFPA 13, Section 16.1.4, 17.1.4, or 18.2.1.
- N. The location, make, model, type, and automatic link temperature of the automatic/manual release smoke vents. In sprinklered buildings, the fusible links for smoke and heat vents shall operate at a temperature no less than 100 degrees above the sprinkler rating. In non-sprinklered buildings, the fusible links shall operate between 100 and 220 degrees above the ambient temperature. Gravity-operated drop-out vents shall operate at 500 degrees.

Note: New construction shall only use approved/labeled smoke vents as specified by CFC 910.3.1. Required smoke vents in existing structures (constructed under the 1998 or previous codes) shall be inspected for proper operation (manual & automatic) and proper link temperature by an independent qualified contractor. Non-required existing vents shall be either treated as a required vent or shall have the automatic and manual mechanism deactivated including the removal of the release handles. An inspection report by the inspecting contractor shall be provided to OCFA **prior to plan approval**. The report, at a minimum, shall identify the year the building was constructed, a roof plan showing the location of each vent inspected, the fusible link temperature rating, the presence of a manual release mechanism, and the operational status of each vent. Prior to submitting the report to OCFA, all identified deficiencies must be corrected and included within the report. If the smoke vents do not contain manual release devices, and OCFA determines that the manual release devices were not specifically required at the time of construction or during any previously approved HPS use, then manual release devices will not be required. OCFA staff will evaluate all other conditions on a case by case basis during the review process. If this requirement is placed, OCFA staff will indicate the requirement adjacent to the OCFA approval stamp on the final approved plans from the proposed operation. The vent inspection report shall be copied onto the plans prior to OCFA plan approval. A new inspection report will not be required when establishing HPS in an existing building where the building owner can demonstrate that the smoke and heat vents have been maintained and inspected per NFPA 204.

- O. If required, the design (construction), location, and depth of the curtain board assembly, if applicable.
 - P. The occupancy group as defined by CBC Chapter 3.
 - Q. Pallet/commodity stop details for maintaining the required flue space (see Attachments 2-5, 7 & 8).
 - R. OCFA requires that the HPS Minimum Information Form (Attachment 9) be completed and copied onto the first sheet of the HPS plan.
3. **Approved Storage Layout:** A floor plan of legible size, shall be provided, mounted on a wall and protected from damage. The floor plans shall be mounted on an

approved location and show the following details. **All** of the following information shall be included per CFC 3201.2, items #A-I:

- A. Location, dimensions, and rack layout of HPS areas.
 - B. Design Storage Heights for each storage area.
 - C. Types of commodities.
 - D. Commodity clearance between top of storage and the sprinkler deflector for each storage arrangement.
 - E. Aisle dimensions between each storage array.
 - F. For palletized and solid pile storage, the maximum pile volume for each storage array.
 - G. Location and classification of commodities in accordance with Section 3203.
 - H. Location of required fire department access doors.
 - I. Location of valves controlling the water supply of ceiling and in-rack sprinklers.
4. Fire safety and evacuation plans shall be provided where required by Section 403 CFC 3201.4.
5. Commodity Classification - CFC 3203: Commodities shall be classified as Class I, II, III, IV, or High Hazard, in accordance with CFC Chapter 32 and referenced standards. Where plastic pallets are used, the commodity classification, determined in Section 3203.8 or 3203.9, shall be modified in accordance with Sections 3203.10.1 through 3203.10.3.

Plastics shall be classified as Group A, B, or C in accordance with CFC Chapter 32. To determine the proper commodity classification of products with limited quantities of Group A plastics in mixed commodities, use CFC Figures 3203.9 (1) and 3203.9 (2). These figures identify the quantity of Group A plastics allowed to be stored in a package, carton, or on a pallet without increasing the hazard and commodity classification to "high hazard".

The percentage by weight of Group A unexpanded plastics in the load shall be calculated in accordance with Equation 32-1. The percentage by volume of Group A expanded plastics in the load shall be calculated in accordance with Equation 32-2. The percentage by weight of Group A expanded plastics in the load shall be calculated in accordance with Equation 32-3. (CFC 3203.9.2)

The designation and protection feature of a high-piled combustible storage area intended for storage of different commodity classes shall be based on the highest hazard commodity stored, except as otherwise provided for by engineering analysis in CFC 3204.2.

Note: Flammable liquids, flammable solids, flammable gasses, aerosols, explosives, oxidizers, and reactive materials, etc. fall under the category of hazardous materials and have additional codes that apply. Storage of hazardous materials often shall require submittal and approval of additional plans prior to further review of the HPS plan.

6. General FIRE PROTECTION Provisions - CFC 3206: Fire protection features for HPS areas shall be in accordance with CFC Chapter 32 and other nationally recognized standards approved by the OCFA. Fire-detection systems, smoke and heat removal, curtain boards, and fire sprinkler design densities shall extend to 15 feet beyond the HPS area or to a permanent partition, whichever is least. (CFC 3206.2)

The aggregate of all HPS areas within a building shall be used to design the fire protection features found in CFC Table 3206.2 (attached), unless such areas are separated from each other by: a one-hour fire barrier wall constructed in accordance with CBC 707, or storage areas separated by 100 feet or more. The area provided for separation shall not contain high-piled combustible storage. Distinct occupancy groups shall be separated according to CBC 508.

7. Fire Sprinkler Systems - CFC 3206.4: When fire sprinklers are required by CFC Table 3206.2 or the CBC (or if otherwise provided), the sprinkler system shall be installed in accordance with NFPA 13 or other applicable NFPA codes. A full description of the tables, figures, and curves in NFPA 13, Section 12 through 18 (Storage), shall be used to determine the design criteria required.
8. Fire Detection Systems - CFC 3206.5: When fire detection is required by CFC Table 3206.2, an approved automatic fire detection system shall be installed in accordance with NFPA 72 standard throughout the HPS area. This system shall be installed and monitored as required by CFC 907.
9. Fire Department Access - CFC 3206.7: When building access is required by CFC Table 3206.2, access roadways shall be provided to within 150 feet of all portions of the exterior walls of the building used for HPS. When access doors are required by CFC Table 3206.2, they shall be provided in each 125 lineal feet or fraction thereof, of the exterior wall that faces the required access roadway. The required access doors shall be distributed such that the lineal distance between adjacent doors does not exceed 125 feet. *Exception: The linear distance between adjacent access doors shall not exceed 200 feet in existing buildings where a change in occupancy is not proposed.*

Access doors shall be accessible without the use of a ladder. Roll-up doors shall not be used unless approved. Only approved locking devices shall be used. Where fire department access doors are required, a key box shall be installed in accordance with Section 506.1. The key box shall contain keys or devices to allow for entry through the fire department access doors. (CFC 3206.7.8)

Fire department access doors shall be labeled on the exterior side. (CFC 3206.7.4)

10. Smoke and Heat Removal - as required per CFC 3206.7 and installed per CFC 910: When smoke and heat removal is required by CFC Table 3206.2, heat and smoke vents (installed in accordance with CFC 910.3) or a mechanical smoke removal system (installed in accordance with section 910.4) shall be of an

approved type and shall operate automatically by a heat response device and contain a manual release roof handle. Vent size shall be in accordance with CFC 910.3.3 and equations 9-4 or 9-5. The fusible link temperature shall be rated as specified in Section 1-N.

Smoke and heat vents are not required per this chapter, when storage areas have an exit access travel distance of 250 feet or less and are protected by early suppression fast response (ESFR) sprinkler systems or control mode special application sprinklers, with a respond time index of 50 or less, are listed to control a fire in the stored commodities with 12 or fewer sprinklers installed in accordance with 2016 NFPA 13 Section 903.3.1.1. Smoke vents shall be inspected and maintained in accordance with 2015 NFPA 204.

11. Draft Curtains: Where ESFR sprinkler systems are installed adjacent to sprinkler systems with standard-response sprinklers, a draft curtain of noncombustible construction and at least 2 feet in depth shall be required to separate the two areas. (NFPA 13)
12. Rack Flue Spaces - CFC 3208.3: Requirements for flue spaces within the rack storage are provided in CFC Table 3208.3 (attached). Single and double row racks shall be equipped with a transverse flue space. A mechanical means shall be provided to maintain the transverse flue space at the uprights (Attachment 7, Method 1). The device and its installation method shall be identified on the plan. Transverse flue spaces between uprights shall be marked with a 1.5, 3 or 6 inch yellow strip on the load beam with words in red that read, "Keep Clear," as indicated below. Durable vinyl tape, paint, or other methods as approved by OCFA may be used.

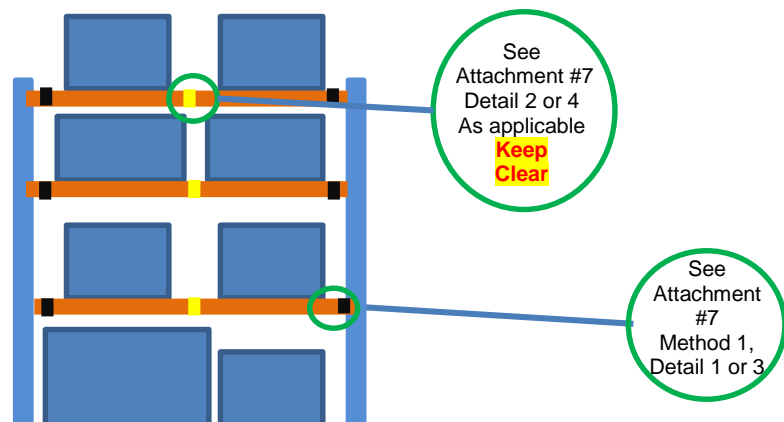

Double-row racks shall be equipped with a pallet/commodity stop along the longitudinal flue space at each level. The stop along the longitudinal flue space shall be steel or other ferrous material ¼ inch thick and, in the mounted position, shall extend a minimum of 4 inches above the shelf or cross member, or other method (i.e., 9 gauge chain link) approved by the fire code official (CFC 3208.3; see Attachments 1-5 & 8). The device and its installation method shall be identified on the plan. In double row racks, where products are hand-stacked, chain link shall be securely attached to the rear of both racks. The chain link shall be a minimum

of 12 gauge. Attachment method shall be in compliance with Figure 3208.3 (Attachment 6) or other methods as approved by the fire code official.

Note: Regardless of the design of the pallet stop, the flue space shall be measured from the back of the pallet stop to the back of the pallet stop (see Attachment 8).

Transverse flue space is measured as the distance between the loads, not the distance between the racks. A flue space's net width is a measure of its gross width minus any horizontal obstructions, such as rack uprights, located within the flue space. In other words, a rack upright (typically 3 in. wide) is not considered a flue space, due to the cross bracing used.



Unless ACCEPTABLE



ACCEPTABLE METHOD

13. Solid Piled and Shelf Storage: Shelf storage, storage in solid piles, solid piles on pallets, and storage in bin boxes not exceeding 5 feet in any dimension shall be in accordance with CFC 3206 and 3207.
14. Rack Storage: Rack storage in a non-sprinklered building shall be in accordance with CFC 3206 and 3208. Rack storage in a sprinklered building shall be in accordance with CFC 3206 and 3208; however the sprinklered protection for solid shelves shall be based on NFPA 13 definition for solid shelves.

Where sprinklers are required for reasons other than those in Chapter 32, the portion of the sprinkler system protecting the HPS area shall be designed and installed in accordance with Section 3207 and 3208.

15. Column Protection: Where fireproofing of building columns is not provided and storage heights are in excess of 15 feet, protection of building columns located wholly or partially within the rack footprint inclusive of flue spaces or within 12 inches of the footprint shall be protected in accordance with one of the options in NFPA 13 Section 16.4.1.
16. In-Rack Sprinklers: In-rack sprinklers shall be located at an intersection of transverse and longitudinal flues spaces not exceeding the maximum spacing rules NFPA 13 Section 16.1.8.4.
17. Automated Storage: Automated storage similar to carousel storage shall be in accordance with CFC 3209.

18. Specialty Storage - CFC 3210: Record storage facilities used for rack or shelf storage of combustible paper records greater than 12 feet in height shall be in accordance with CFC 3206, 3208, and NFPA 13. Palletized storage of records shall be in accordance with CFC 3207.

MAINTENANCE

CFC Chapter 9

All fire and life safety equipment and systems required by the CFC shall be maintained operable at all times. Equipment, devices, and systems shall be regularly tested in accordance with nationally recognized standards, manufacturer recommendations, and adopted regulations.

The responsibility for inspections, maintenance of the HPS areas as approved, and all fire and life safety equipment and systems required by the CFC shall be the ultimate responsibility of the building owner provided that this responsibility has not been transferred in written form to a management company or other party via a lease agreement or other legal document.

DO NOT STORE ABOVE THE YELLOW LINE

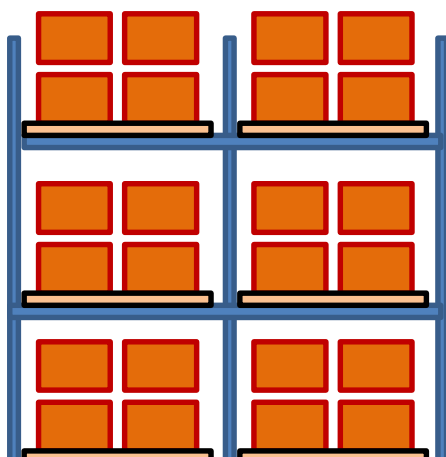

Note: As required by the fire code official, a visual method of indicating the maximum allowable storage height shall be provided. (CFC 3205.6)

APPROVED PLANS

CFC Chapter 3201.3

A copy of the approved HPS plans shall be signed by the OCFA Fire Inspector upon issuance of the permit. This copy of the plans shall be maintained on site for the life of the HPS system. OCFA shall be consulted prior to any changes in the approved/existing/permitted HPS system(s).

TECHNICAL ASSISTANCE

Due to the complexity of the designs specified within the CFC and adopted standards, it may be necessary to obtain the service of a fire protection design professional to assist with developing a protection scheme that meets the requirements of the CFC and other applicable regulations.

TABLE 3206.2: GENERAL FIRE-PROTECTION AND LIFE-SAFETY REQUIREMENTS

Commodity Class	Size of High-Piled Storage Area ^a (square feet) (See Sections 3206.2 and 3206.3)	ALL STORAGE AREAS (See Sections 3206, 3207 and 3208) ^b				SOLID-PILED STORAGE, SHELF STORAGE AND PALLETIZED STORAGE (See Section 3207.3)		
		Automatic Fire-extinguishing System (See Section 3206.4)	Fire-detection System (See Section 3206.5)	Fire Department Access Doors (See Section 3206.7)	Smoke and Heat Removal (See Section 3206.8)	Maximum Pile Dimension ^c	Maximum Permissible Storage Height ^d (feet)	Maximum Pile Volume (cubic feet)
I-IV	0-500	NR ^a	NR	NR ^e	NR	NR	NR	NR
	501-2,500	NR ^a	Yes ⁱ	NR ^e	NR	100	40	100,000
	2,501-12,000 Open to the public	Yes	NR	NR ^e	NR	120	40	400,000
	2,501-12,000 Not open to the public. (Option 1)	Yes	NR	NR ^e	NR	120	40	400,000
	2,501-12,000 Not open to the public. (Option 2)	NR ^a	Yes	Yes	Yes ^{h,i}	120	30 ^c	200,000
	12,001-20,000	Yes	NR	Yes	Yes ^{h,i}	100	40	400,000
	20,001-500,000	Yes	NR	Yes	Yes ^{h,i}	100	40	400,000
	Greater than 500,000	Yes	NR	Yes	Yes ^{h,i}	100	40	400,000
High-hazard	0-500	NR ^a	NR	NR ^c	NR	60	NR	NR
	501-2,500 Open to the public	Yes	NR	NR ^e	NR	60	30	75,000
	501-2,500 Not open to the public (Option 1)	Yes	NR	NR ^e	NR	60	30	75,000
	501-2,500 Not open to the public (Option 2)	NR ^a	Yes ^g	Yes	Yes ^{l,j}	60	20	50,000
	2,501-300,000	Yes	NR	Yes	Yes ^{l,j}	60	30	75,000
	Greater than 300,000 ^f	Yes	NR	Yes	Yes ^{l,j}	60	30	75,000

NR = Not Required

- When fire sprinklers are required for reasons other than those in Chapter 32, the portion of the sprinkler system protecting the high-piled storage area shall be designed and installed in accordance with Sections 3207 and 3208.
- For aisles, see Section 3206.0.
- Piles shall be separated by aisles complying with Section 3206.0.
- For storage in excess of the height indicated, special fire protection shall be provided in accordance with Footnote (g) when required by the chief. Also see Chapters 51 and 57 for special limitations for aerosols and flammable and combustible liquids, respectively.
- For storage exceeding 30 feet in height, Option 1 shall be used.
- Special fire protection provisions including, but not limited to, fire protection of exposed steel columns; increased sprinkler density; additional in-rack sprinklers, without associated reductions in ceiling sprinkler density; or additional fire department hose connections shall be provided when required by the Fire Chief.
- HPS areas shall not exceed 500,000 square feet. A two-hour fire wall constructed in accordance with the CBC shall be used to divide HPS exceeding 500,000 square feet in area.
- Not required when an automatic fire-extinguishing system is designed and installed to protect the HPS area in accordance with Sections 3207 and 3208.
- Smoke and heat vents are not required when storage areas with an exit access travel distance of 250 feet or less are protected by either early suppression fast response (ESFR) sprinkler systems installed in accordance with NFPA 13 or control mode special application sprinklers with a response time index of 50 (m • s)^{1/2} or less that are listed to control a fire in the stored commodities within 12 or fewer sprinklers, installed in accordance with Section 903.3.1.1.
- Heat and smoke vents are not required in frozen warehouse(s) used solely for storage of Class I and/or Class II commodities where protected by an approved automatic sprinkler system.

**TABLE 3208.3
REQUIRED FLUE SPACES FOR RACK STORAGE**

RACK CONFIGURATION	FLUE DESIGN		AUTOMATIC SPRINKLER PROTECTION		
			Sprinklers at the ceiling with or without minimum in-rack sprinklers		In-rack sprinklers at every tier
			Storage height ≤ 25 feet	Storage height > 25 feet	Any height
Single-row rack	Transverse flue space	Size ^b	3 inches	3 inches	Not required
		Vertically aligned	Not required	Yes	Not required
	Longitudinal flue space		Not required	Not required	Not required
Double-row rack (Option 1)	Transverse flue space	Size ^b	6 inches ^a	3 inches	Not required
		Vertically aligned	Not required	Yes	Not required
	Longitudinal flue space		Not required	6 inches	Not required
Double-row rack (Option 2)	Transverse flue space	Size ^b	3 inches	6 inches	Not required
		Vertically aligned	Not required	Yes	Not required
	Longitudinal flue space		6 inches	Not required	Not required
Multiple-row rack	Transverse flue space	Size ^b	6 inches	6 inches	Not required
		Vertically aligned	Not required	Yes	Not required
	Longitudinal flue space		Not required	Not required	Not required

For SI: 1 inch = 25.4 mm, 1 foot = 304.8 mm.

- a. Three-inch transverse flue spaces shall be provided not less than every 10 feet where ESFR sprinkler protection is provided.
- b. Random variations are allowed, provided that the configuration does not obstruct water penetration.

ATTACHMENT 1

LOAD BEAM CONFIGURATION NOT REQUIRING PALLET STOPS

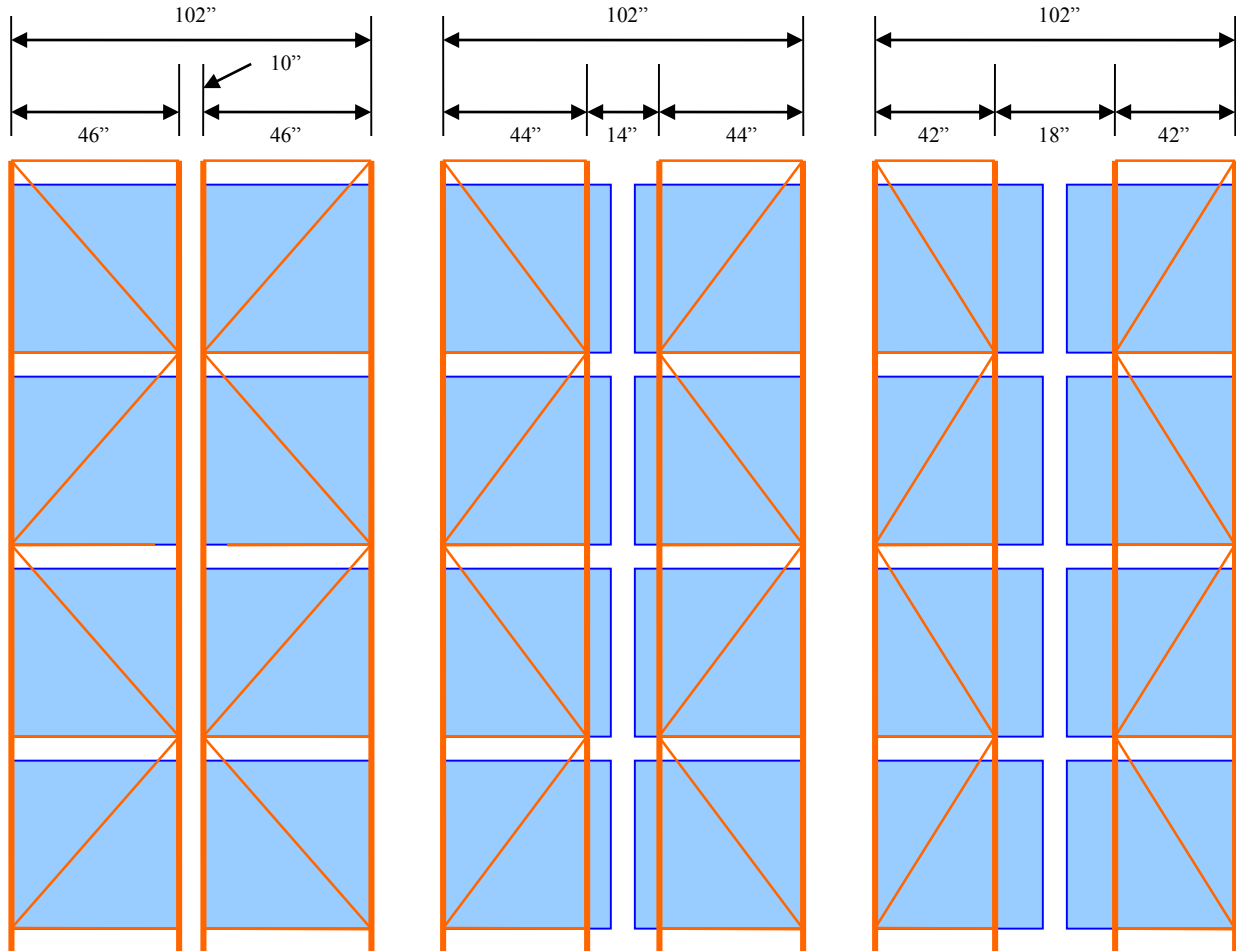

NOTES:

1. MAXIMUM PALLET DEPTH 48"
2. STORAGE ON LOAD BEAM ONLY, NO SHELVING, WIRE MESH GRATING, OR PALLET SUPPORTS.
3. 6" FLUE SPACE SHALL BE MAINTAINED AT ALL TIMES.
4. CHANGE TO THE STORAGE CONFIGURATION REQUIRES PRIOR OCFA APPROVAL.

NOTES:

1. WHEN 42" UPRIGHTS ARE UTILIZED WITH AN 18" ROW SPACER AND A TYPICAL 48"x40" PALLET IS USED, NO PALLET STOPS ARE REQUIRED.
2. WHEN 44" UPRIGHTS ARE UTILIZED WITH A 14" ROW SPACER AND A TYPICAL 48"x40" PALLET IS USED, NO PALLET STOPS ARE REQUIRED.
3. WHEN 46" UPRIGHTS ARE UTILIZED WITH A 10" ROW SPACER AND A TYPICAL 48"x40" PALLET IS USED, NO PALLET STOPS ARE REQUIRED.

ATTACHMENT 2

STORAGE CONFIGURATION REQUIRING PALLET STOPS

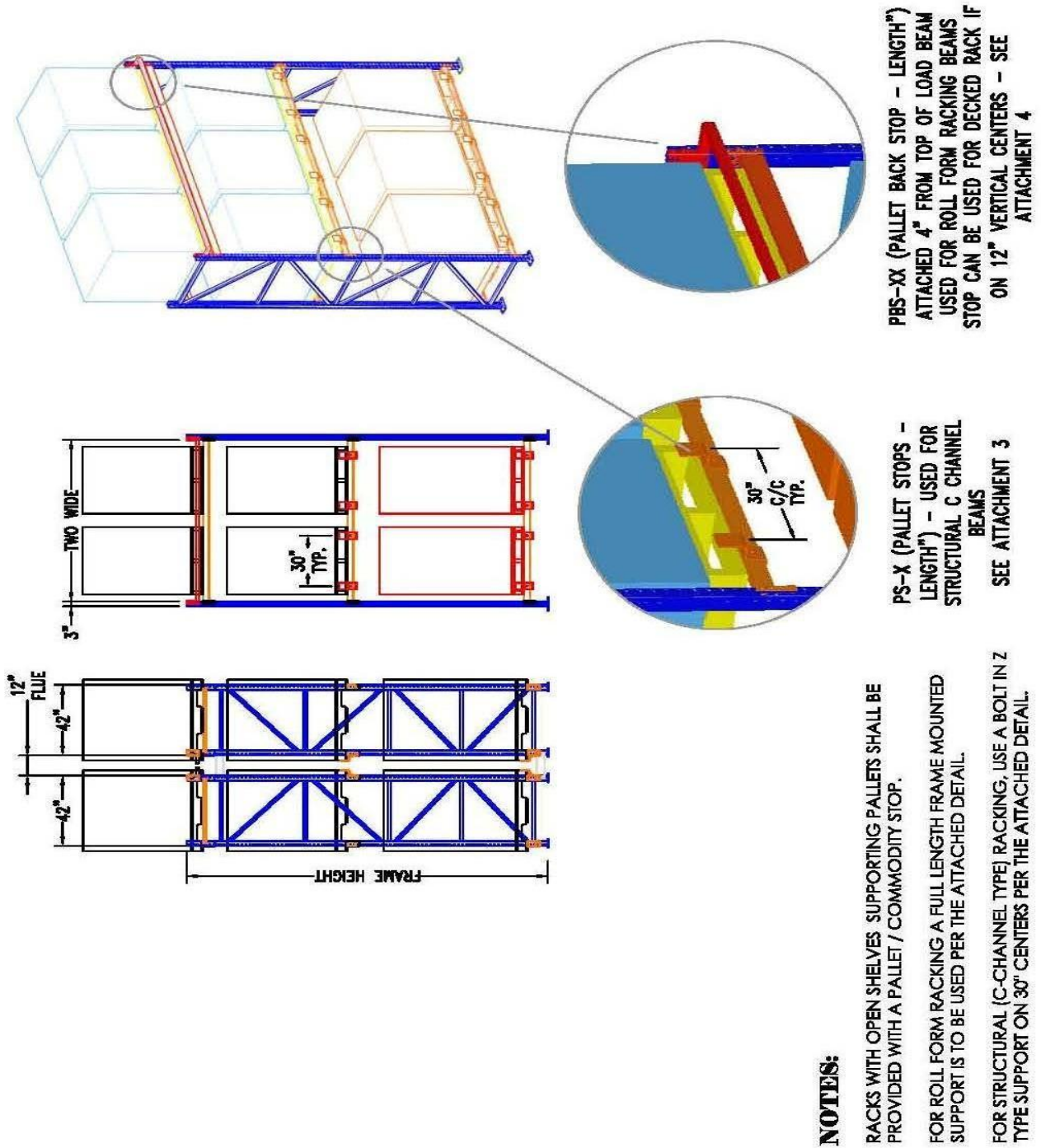

ATTACHMENT 3

STRUCTURAL "C" CHANNEL BEAM DETAIL

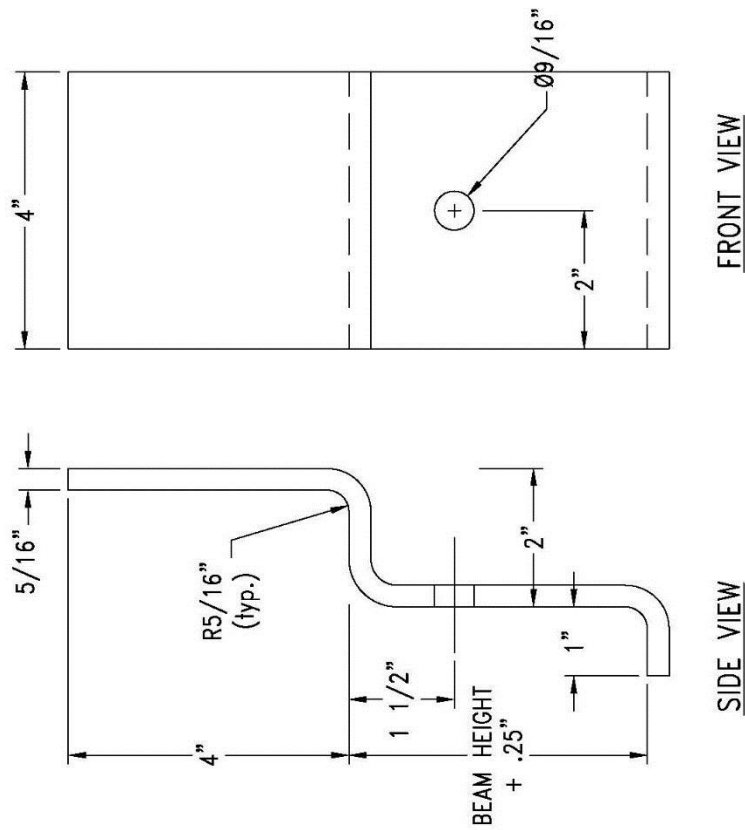

ATTACHMENT 4

ROLL FORM RACKING DETAIL

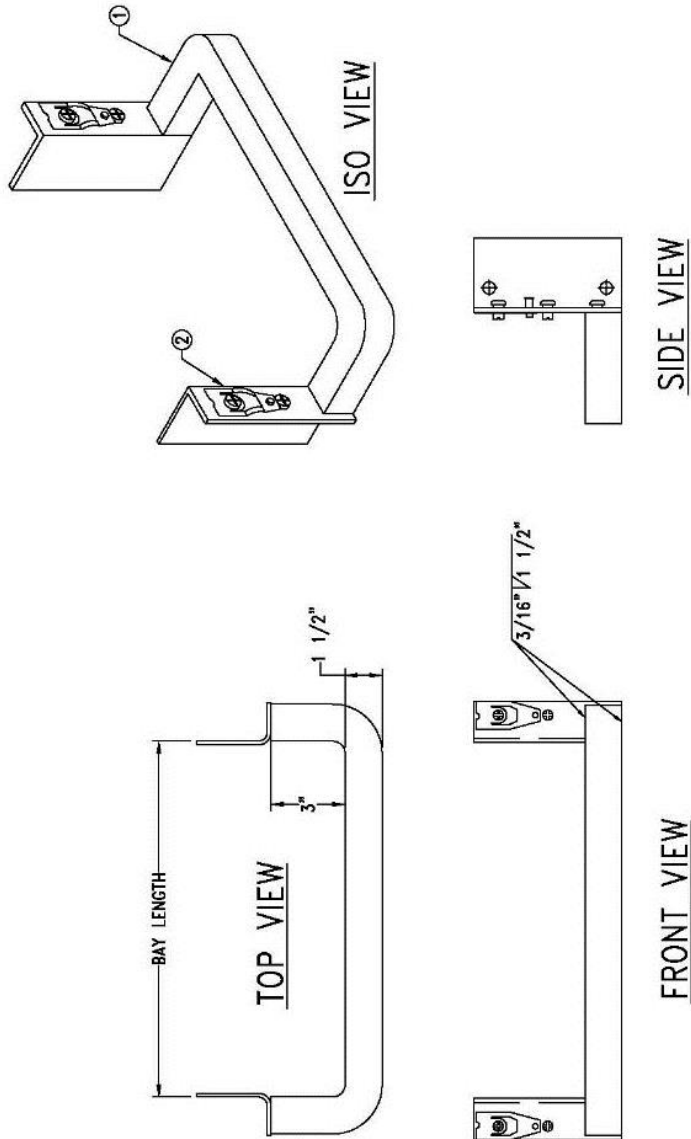

ATTACHMENT 5

STORAGE CONFIGURATION FOR HAND STACK RACK

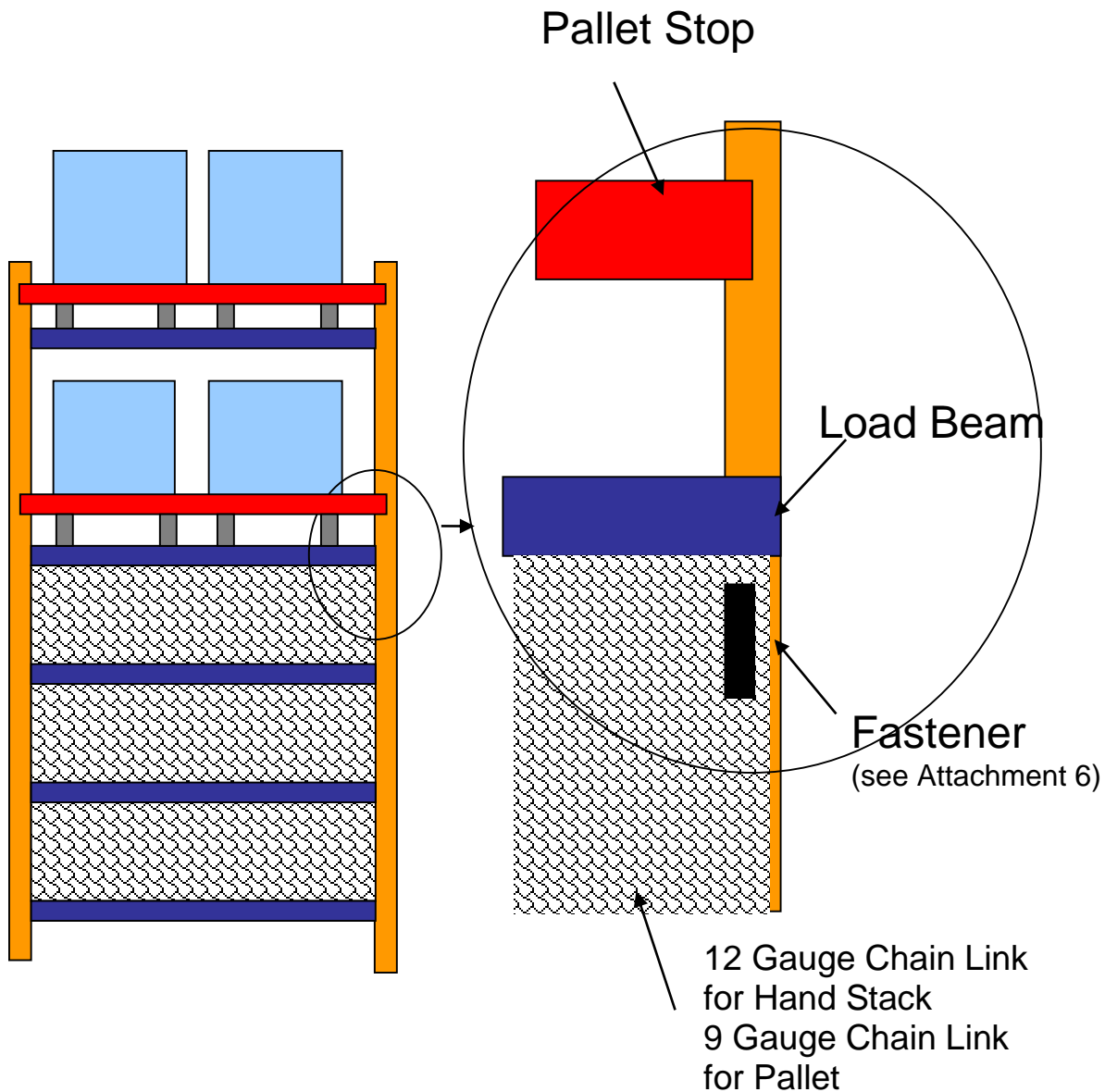

NOTES:

HAND STACKING/PICKING RACKS: HAND STACKING NON-PALLETIZED AREAS SHALL BE PROVIDED WITH A MEANS TO ENSURE THAT THE FLUE SPACES ARE MAINTAINED. HAND STACK LOCATION WILL BE SECURED FLUSH TO THE REAR COLUMN OF EACH FRAME AS SHOWN IN ATTACHED DETAIL (SEE ATTACHMENT 6 FOR CHAIN LINK).

9 Gauge Chain Link Fence for Pallet Loads.

12 Gauge Chain Link for Hand Stack Loads.

ATTACHMENT 6

CHAIN LINK ATTACHMENT METHOD DETAIL

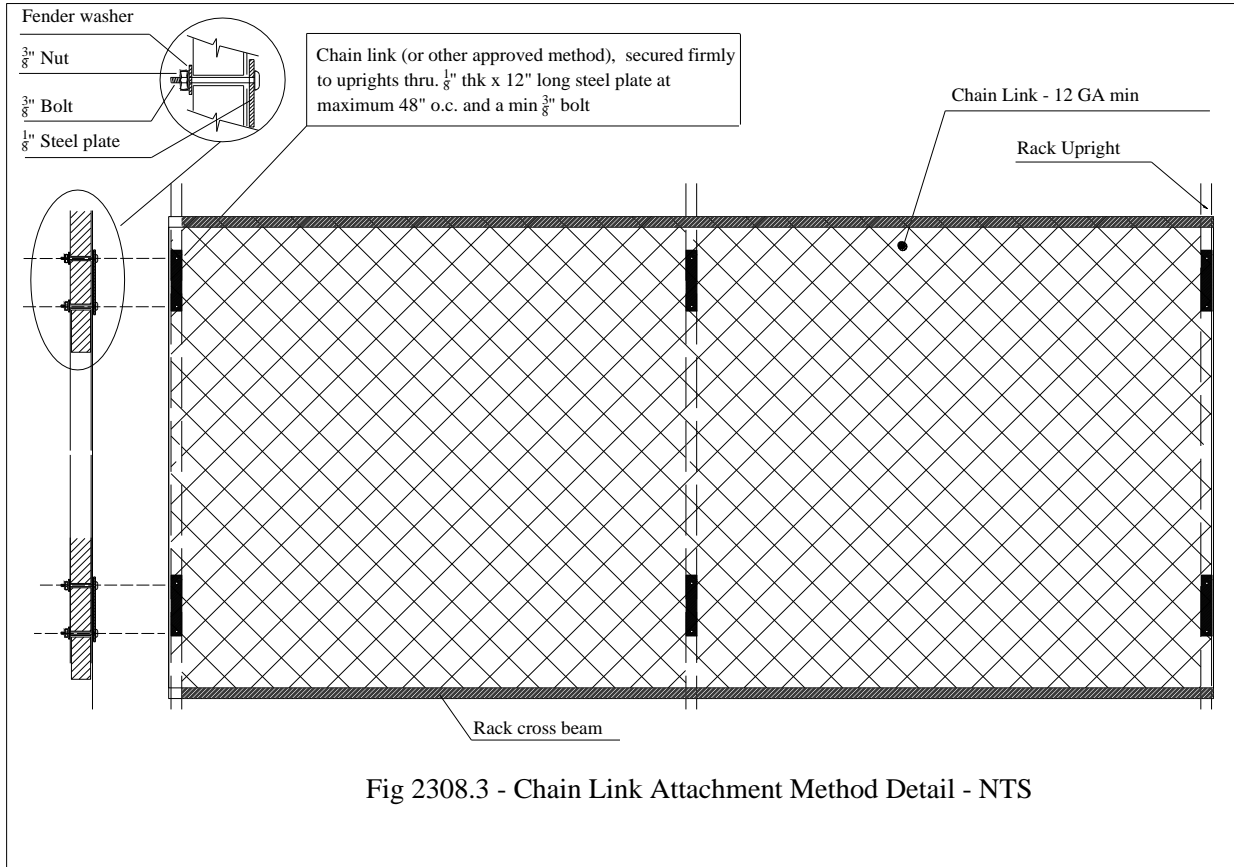
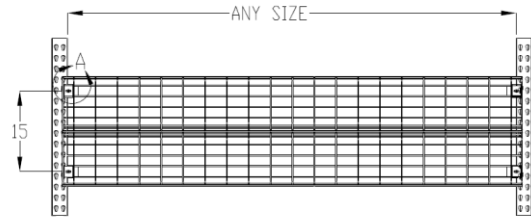
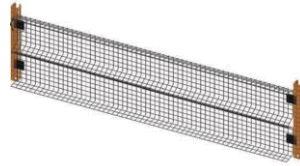

Fig 2308.3 - Chain Link Attachment Method Detail - NTS

ATTACHMENT 7



Method 1



Method 2

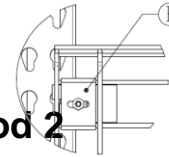

AISLE SHIELD

DETAIL 1

**MECHANICAL ENFORCEMENT DEVICE AT RACK COLUMN
(NET 3" TRANSVERSE FLUE)**

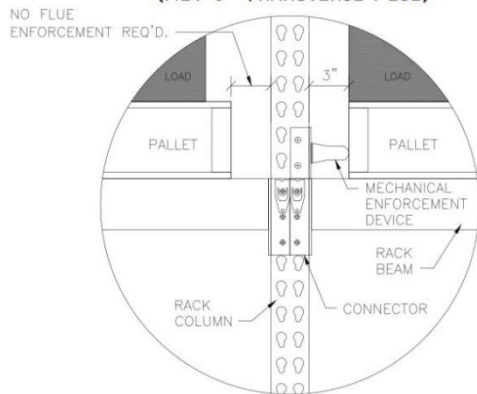

NOTE: TO BE USED WITH DETAIL 2 ONLY

DETAIL 2

**3" TRANSVERSE FLUE LABEL
BETWEEN PALLET LOADS**

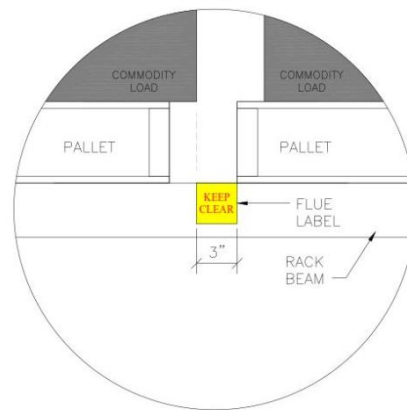

NOTE: TO BE USED WITH DETAIL 1 ONLY

DETAIL 3

**MECHANICAL ENFORCEMENT DEVICE AT RACK COLUMN
(NET 6" TRANSVERSE FLUE)**

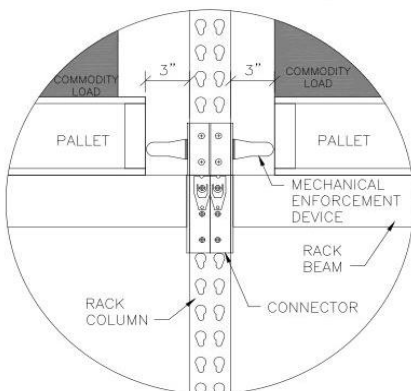

NOTE: TO BE USED WITH DETAIL 4 ONLY

DETAIL 4

**6" TRANSVERSE FLUE LABEL
BETWEEN PALLET LOADS**

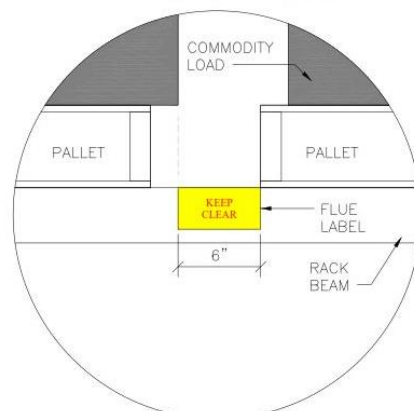

NOTE: TO BE USED WITH DETAIL 3 ONLY

ATTACHMENT 8

Pallet Stop Longitudinal Flue Clear Space

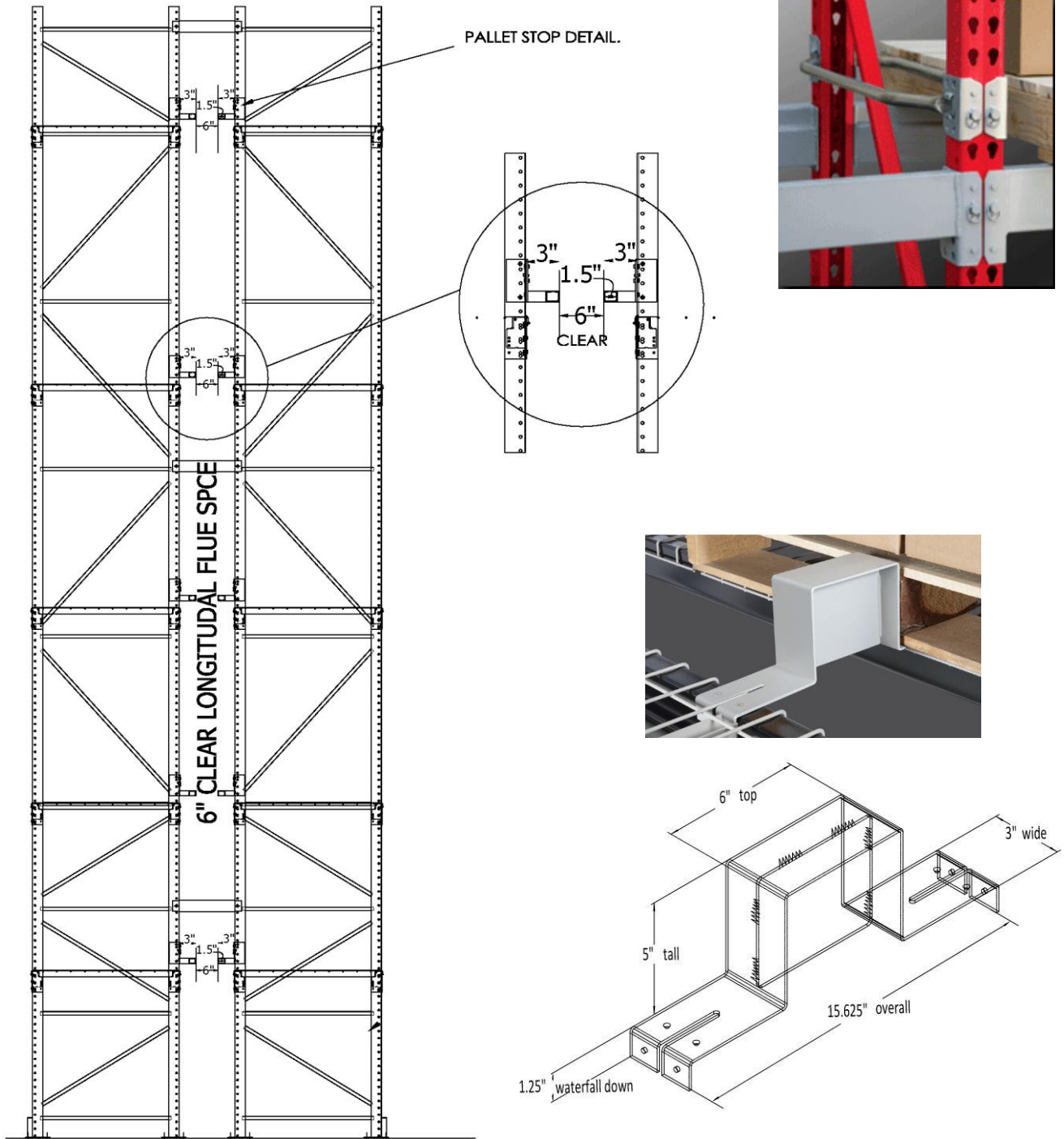



ORANGE COUNTY FIRE AUTHORITY

NOTES FOR HIGH PILED STORAGE

PLACE THE FOLLOWING NOTES VERBATIM ON THE PLAN UNDER "FIRE DEPARTMENT NOTES":

- a) Fire Department inspection required. Schedule 2 days in advance, @714-573-6150.
- b) A CFC permit is required for HPS and will be issued by an OCFA inspector.
- c) Locations and classifications of extinguishers shall be in accordance with CFC 906.2 and Chapter 3, Title 19 CCR and placement is subject to the approval of the fire inspector.
- d) Storage, dispensing or use of any flammable/combustible materials and other hazardous materials shall comply with CFC regulations.
- e) Exit doors shall be openable from the inside without the use of a key or any special knowledge or effort.
- f) Modification to fire sprinkler and alarm systems shall comply with 2016 NFPA 13 and 72. A separate plan submittal is required.
- g) Fire sprinkler systems and all control valves shall be monitored by a U. L. listed central alarm station or be supervised per 2016 CFC Chapter 9. A separate plan submittal is required for the installation of the monitoring system.
- h) Fire apparatus access roads shall be unobstructed. Access gates shall be approved prior to installation and shall be in compliance with CFC 504 and OCFA guidelines.

ATTACHMENT 9

The following form shall be completed for each storage configuration and/or storage area. The completed form shall be copied onto the HPS plans for all projects within OCFA jurisdiction:

Commodity Classification:

- I II III IV High Hazard Group A plastic . Fill in commodity description at the bottom of page.
- Cartoned Free flowing Non-expanding Encapsulated Non-encapsulated
- Other _____

- The area designated in the building and used for high piled storage is _____ square feet.
 CLASS _____ commodity, _____ sq. ft.
 CLASS _____ commodity, _____ sq. ft.
 CLASS _____ commodity, _____ sq. ft.

- The maximum permitted storage height (solid pile _____ rack _____)

The following storage methods are employed at this facility:

- Solid pile storage Palletized Single row rack Double row rack Multi-row rack
- Other _____

- Rack storage shelf: N/A Load beam only Wire mesh Wood slates Plywood
- Other (Describe): _____

- Minimum distance between top of storage and sprinkler _____

- Smoke vents required Yes No

Operation of smoke vents (if applicable)

- Manual
- Automatic via fusible link which releases at _____ °F. (Note: New installations require manual & automatic release)
- Inspection Report shall indicate which vents were tested

- Draft Curtains Required? Yes No

- The overhead fire sprinkler system utilizes the following heads:

- ESFR: K _____ at _____ PSI with _____ °F heads
- Standard Coverage Heads: K _____ Pendant Upright _____ degree with a density of _____ gpm over _____ square feet spaced at a maximum of _____ square feet per fire sprinkler.

- The fire sprinkler system density and area of application for the storage area is _____ gpm/ft² over _____ ft²

- In-rack sprinklers required Yes No

There is/are _____ level(s) of in-rack fire sprinkler protection.

- The aisles between the racks shall be maintained at _____ feet.

- Fire Doors required? Yes No

- Flue Spaces required? Yes No

- Flue space between racks shall be maintained a minimum of:

 Transverse _____" clear. Must be vertically aligned (for storage >25')

 Longitudinal _____" clear

- Column protection required? Yes No because,

- Pallet Stops Required? Yes No because, _____.

Longitudinal pallet stop configuration:

- Chain Link Roll Form "C" Channel Other _____

Transverse Flue Pallet Stop configuration:

- Mechanical means (flue keepers, etc.) Load beam markings "Keep Clear"
- Hand Stack? Yes No # of tiers: _____ Chain link required Yes No

- Idle pallet floor storage shall not exceed 5 feet. Yes No.

Idle pallets are **NOT** permitted to be stored in the racks.

- Storage configuration and height delineated by indication on floor or walls and or ceiling. Yes No

- Additional conditions: _____

Are there any hazardous materials stored in the High Piled Storage Area?

- Yes - Provide the Service Request (SR#) for the approved hazardous material review - **SR#** _____

- No - Provide a note on the plans stating, "No hazardous material storage allowed without OCFA approval."

Commodity description. Include packaging materials, if applicable say none:

ATTACHMENT 10

Do I need to submit a high-piled storage plan to OCFA?

Use the following flow chart to determine whether you have High Piled Storage (HPS) that requires review and approval by OCFA via a plan submittal. To qualify, the answer to each of the three questions in the blue boxes must be “yes.” Additional clarifying information for each question is provided in the footnotes.

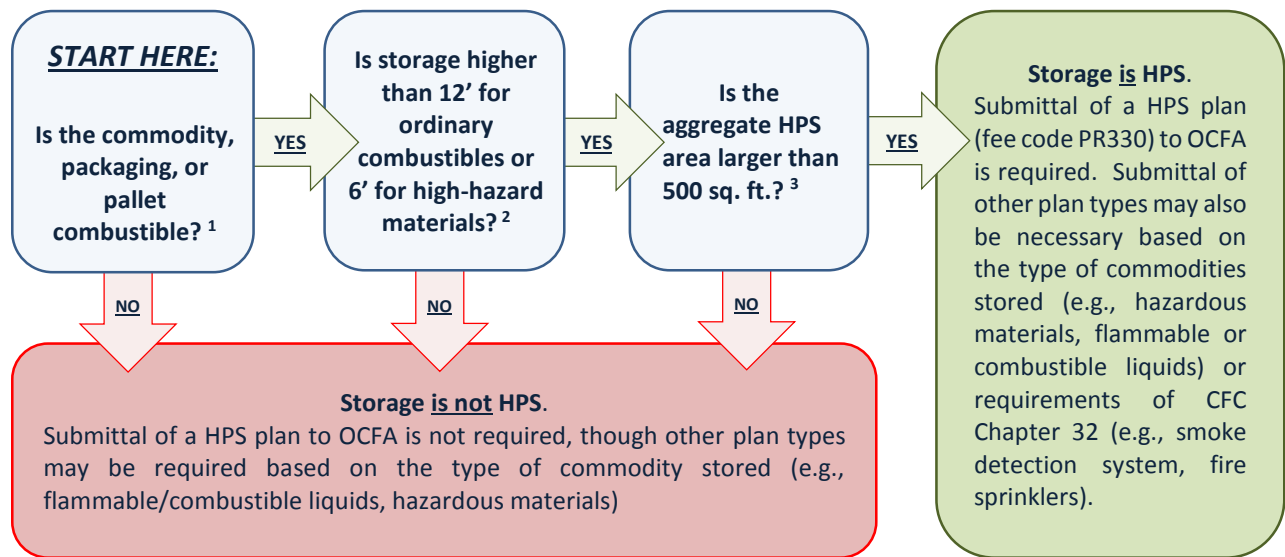

FOOTNOTES:

- 1. Is any part of the commodity, including its packaging or pallet, combustible?**
 - An example of non-combustible commodity storage would be metal engine parts stored directly on metal skids; metal parts on wood pallets or stored in cardboard boxes or plastic bins/bags are considered combustible because of the pallets or packaging.
- 2. Is the storage height greater than 12 ft. for ordinary combustibles and/or greater than 6 ft. for high-hazard combustibles?**
 - Storage height is measured to the top of the commodity, not the rack or shelf the commodity is stored on. The stated maximum storage height needs to be within reason relative to rack or shelf heights; for example, 18 ft. racking/shelving is proposed but storage is stated to be kept to 12 ft. with no physical means to limit storage height; this should be reviewed as HPS.
 - Ordinary combustibles include, but are not limited to: wood and paper products; natural and synthetic fabric/clothing (other than rayon); food products; Level 1 or 2 aerosols; water-based paint in plastic containers or oil-based paint; wood or metal furniture with combustible components (padding, upholstery); and similar products.
 - High-hazard combustible commodities include, but are not limited to: plastic; rubber, foam rubber and foam plastic; tires; storage of idle pallets; Level 3 aerosols; lacquers and solvents; flammable or combustible liquids; rayon fabric/clothing; mattresses; and similar products and materials.
 - Any combustible storage above or below high-hazard combustibles is considered as part of the high-hazard combustible storage overall height
- 3. Is the aggregate HPS area greater than 500 sq. ft.?**
 - HPS area definition: An area within a building that is designated, intended, proposed, or actually used for high-piled combustible storage.
 - Aggregate area for rack storage shall include:
 - The “footprint” of the actual HPS rack storage array, inclusive of aisles within the storage area(s). When individual storage arrays are separated by less than 15 ft. spaces, the spaces shall be considered aisles and shall be included in a single storage area footprint. When individual storage arrays are separated by more than 15 ft. spaces, the individual arrays shall be considered separate storage areas with their own footprint calculation.
 - A 48-inch perimeter aisle calculated in the footprint. This additional perimeter aisle is not required for areas that abut a wall. The aisle is the space that parallels the rack and does not include open space along the end of the rack.
 - Aggregate area for palletized, solid-piled, and shelf storage shall include:
 - The “footprint” of each palletized, solid-piled and shelf storage array, non-inclusive of aisles.